



## RECYCLING PROCESSING TECHNOLOGY OF PLASTICS

Riskulov A. A.

DSc, Prof. of the Materials Science and Mechanical Engineering Department,  
Tashkent State Transport University

Alimukhamedov Sh. P.

Dr. Tech. sciences, professor  
of the Department of Materials Science and Mechanical Engineering, Tashkent  
State Transport University, Tashkent, The Republic of Uzbekistan

Tursunov N. K.

Ph.D., head of the Department of Materials Science and Mechanical  
Engineering, Tashkent State Transport University, Tashkent,  
The Republic of Uzbekistan,  
e-mail: u\_nadir@mail.ru

Toirov O. T.

Ph.D. student of the Department of Materials Science and Mechanical  
Engineering, Tashkent State Transport University, Tashkent,  
The Republic of Uzbekistan  
e-mail: tv574toirov@mail.ru

Azimov S. J.

Senior lecturer of the Department of Materials Science and Mechanical Engineering,  
State Transport University, Tashkent,  
The Republic of Uzbekistan

Kholmirezayev B

Senior lecturer of the Department of Materials Science and Mechanical Engineering,  
State Transport University, Tashkent,  
The Republic of Uzbekistan

### Abstract

Processing of plastics is a complex of technologic operations which make it possible to manufacture goods or semi-processing goods from plastics with the help of special equipment. Processing of plastics is preceded by development of the product design, selection of the optimum method for treatment, engineering and manufacturing of technologic equipment, development of the formulation of a polymer composition, its





preparation and preparation to molding (granulation, pelletization, etc.). Processing of plastics per se includes molding of products and their subsequent treatment to improve the properties of a polymer material (thermal treatment, radiation cross-linking, etc.)

**Keywords:** Premoldings; thermoreactive press material; sintering; compression molding; high-pressure casting ; extrusion; melt-blowing method; melt-spinning technology; semi-processed products.

## 1. Introduction

Up until the beginning of the 20<sup>th</sup> century, the methods for polymer processing into goods imitated the known methods for processing such materials as clay and soft metals (casting, pressing, forming), and it was not until the middle of the 20<sup>th</sup> century that novel technologic methods for molding of plastics appeared which are based on application of polymer specific properties: pneumatic-and vacuum molding, calendering, etc. Now target methods and techniques for processing of plastics may number into the dozens.

## 2. Methods

In choosing the technology for plastics processing we can use the following classification based on the physical state of a polymer material in shaping the good or molding:

- 1) polymers in a viscous-flow state are processed by extrusion, high-pressure casting, pressing;
- 2) film and laminary intermediates in high elastic state are processed by vacuum molding, warm forming, drawing;
- 3) hard polymers manifesting inducing high elasticity are treated by forming at room temperature, rolling;
- 4) polymer solutions and dispersion are applied in manufacture of films by flowing, forming of casings by dipping of a form, rotational forming of castings from plastisols (pastes based on PVC and plasticizer), application of polymer powder coverings;
- 5) sintering of pressed powder intermediates (pressings) from reactoplasts of thermal plastics with high viscosity in a viscous-flow state (fluoroplasts).

Specific methods for formation of goods from polymer composites are treated in Chapter 27. Thermal plastics goods can often be manufactured by several different methods. The choice of processing method for every specific product is governed by a diversity of factors, with the most important ones being the following:





- Design,
- Technological property of a polymer material,
- Operation conditions of a product, and the resulting requirements for them (surface quality, dimensional accuracy, the presence of accessories, threadings, etc).
- Anticipated product replication,
- Economic and ecologic factors (cost of equipment and accessories, their productivity and durability, labor inputs, qualification of workers, amount of material wastes, possibility of after-processing, etc.).

Thermoplastics are processed into goods with technologic equipment, the operational principle being based on the property of a thermoplastic material being reversibly converted into a viscous-flow state. The following methods for thermoplastic processing received industrial application: extrusion, high-pressure casting, compression forming, sintering and mechanical treatment.

Extrusion (squeezing-out) is a process of manufacturing of goods of required forms and dimensions or elongated profile semi-processed products by heating of polymer granules (granulate) and forcing the polymer mass that is in a viscous-flow state through the forming aperture of extruder head (Figure 1, a).

The main part of a special extruder for squeezing out of melt is a screw (screw conveyer). Thermoplastic as granules or powder 1 comes from a feed hopper into a heated cylinder 4 where it is moved by a rotating screw 3. The material is tightened and under the action of heat coming from a heating element 2 is converted into a thick-flow state. Thereafter it is continuously forced through a calibration instrument (head) 6 as profile 5.

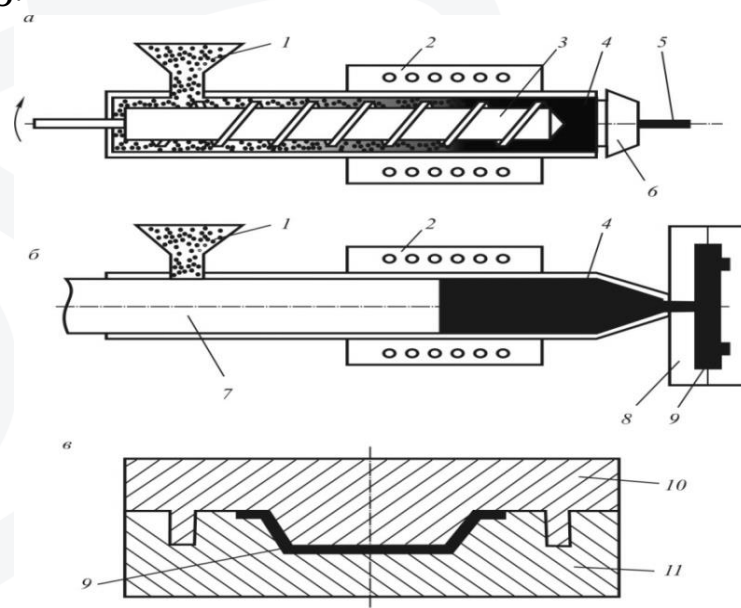

Figure 1. Methods for plastics processing:



a, extrusion (squeezing out), b, high-pressure casting (injection), c, compression forming; 1, granulate, 2, heater, 3, screw conveyer, 4, melt, 5, extruded profile, 6, head, 7, piston (plunger), 8, casting form, 9, cast product (pressing), 10, plug, 11, matrix Flat (sheets), profile (profile (angles, channels) and voluminous (tubes) goods are formed depending on the form of the aperture in the head. By ballooning of the squeezed tube hose stock with the help of air, films of various thickness and length are obtained. To increase strength and decrease thickness of the films, the hose is subjected to one-or two-axis orientation. Special design of heads with extrusion nozzles supplied by a great number of low diameter apertures makes it possible to extrude filaments and fibers. The melt-spinning technology allows for extrusion of fiber with subsequent gravitation drawing and strengthening. The melt-blowing method (spraying of polymer melt by a gas flow) is used for production of fibrous unwoven fabrics with various porosity and density.

Extrusion is one of the most productive methods for processing of thermal plastics. Aggregates with the productivity as high as 10 t/h are created with a great degree of technologic process automatization. Extrusion is used to produce polymer tubes with a 1.5-m diameter and films of 25-m width. A new promising equipment, reactors-extruders, is developed. The processes of melting and polymerization are combined in such instruments. The first specimens of such equipment of 50 kg/h productivity were used for manufacture of polymethylmethacrylate articles.

High-pressure casting is executed with the help of special machines with a plunger and screw injection device (Figure 1, b). Processing of thermoplastics by high-pressure casting is based on heating of the material to a viscous-flow state, its replacement under pressure to a mold and subsequent cooling of the cast providing for stability of its shape. A thermoplastic polymer 1 as granules enters a feed hopper to a cylindrical cavity of an injection machine where the predetermined temperature is maintained. A piston or a plunger 7 which is periodically set into motion squeezes the polymer mass into a divided cooled mold 8 where the end product 9 is being molded. Modern casting machines can mold production weighing in the range from a fraction of a gram to 100 kg.

### 3. Results and Discussion

The high-pressure casting is used to produce a high production mix of items for constructional, antifriction and general purposes. The equity of the method is a high accuracy and quality of the goods, Application of multicavity molds, preliminary heating of raw materials and the high degree of process automatization (completely







automated lines have been developed which are operated by a computer) allow for attainment of high efficiency of equipment application.

Thermoplastics as sheets or films are processed by compression molding. The essence of the method is in forming of a polymer intermediate as a sheet or a film with the help of compressed air (pneumof ormation) or vacuum (vacuum-formation). Compression molding is used for manufacture of large-sized items of a complex configuration: parts of automobiles, casts for television-and radio equipment, hulls of boats, etc.

Sintering is used for processing of thermal plastics with high melting points and great viscosities of the melts (fluoroplasts, high-filled polyolefines). The traditional technology of sintering includes operations of component mixing, pressing of the mixtures in a mold, sintering of the pressing and cooling of the product. The products are sintered at a temperature of  $5...10^{\circ}$  in excess of the melting point of the basic thermoplastic. A protective gas medium (nitrogen, carbon dioxide) is used for prevention of product oxidation.

Reactoplasts are processed into goods by pressing, compression molding, centrifugal molding and winding. The most common method for processing of reactoplasts is pressing: direct (compression), casting (transferring), rotor and continuous profile pressing (extrusion pressing).

General operations for pressing of all types are loading of the press composition into a form, its transition to a viscous-flow state, shaping the blank under pressure, fixation of the product form by formation of a cross-linked structure of the material under pressure and temperature and cooling of the product. In direct, casting and rotor pressings, the products are implemented and the form is fixed in a closed volume, a tool's molding cavity (Figure 1, c). Large-sized products are molded by extrusion pressing during continuous process of plunger pressing combined with heating of the powder composition. The process is completed by squeezing of the product through a nozzle.

The technologic process of manufacturing from a special type of polymer raw materials named press materials includes the following main operations: preparation of materials and their dosing, pressing of tablets, preliminary heating of tableted material, its loading into a molding tool, closing the molding tool, premolding, exposure to pressure, disclosure of the molding tool and withdrawing of the product, cleaning of the molding tool and preparation to the subsequent cycle of molding.

The initial thermoreactive press-powder which has passed through input control is tableted to decrease the volume of the press mass and increase the accuracy of its dosage. To reduce the duration of material exposure to pressure, preliminary heating





of the tablets is carried out at the temperature of reactoplast cross-linking. During heating the binding product is partially cross-linked and the adsorbed low-molecular-weight products are removed. The heating is implemented with IR-heaters or RF current. After closure of the heated matrix and plug of the loaded molding tool, the press material undergoes cross-linking of the polymer binding agent. These are generally polycondensation processes accompanied by release of water and gases. The latter stipulate the porosity of the product, worsening its properties. To remove low-molecular-weight substances from the molding tool, 2 or 3 premoldings are carried out: lifting of the plug for a short time followed by a rapid closure of the molding tool. The premolding duration amounts to 1-5 s.

#### 4. Conclusion

The most prolonged operation of the molding technological cycle is high temperature exposure of the molding tool to pressure which is required for complete hardening of thermoreactive press material. To remove residual strains occurring during molding, the parts are thermally processed.

Transfer molding includes similar technological operations. The constructive feature of the molding tools applied for this method implementation, it the presence of a special loading chamber (precombustion chamber) from which polymer material in a viscous-flow state is squeezed into tool's molding cavity.

#### References:

1. Riskulov, A. A., Yuldasheva, G. B., Kh, N., & Toirov, O. T. (2022). DERIVATION PROCESSES OF FLUORINE-CONTAINING WEAR INHIBITORS OF METAL-POLYMER SYSTEMS. Web of Scientist: International Scientific Research Journal, 3(5), 1652-1660.
2. Riskulov, A. A., Yuldasheva, G. B., & Toirov, O. T. (2022). FEATURES OF FLUOROCOMPOSITES OBTAINING FOR WEARING PARTS OF MACHINE-BUILDING PURPOSE. Web of Scientist: International Scientific Research Journal, 3(5), 1670-1679.
3. Abdurazakov, A. A., Riskulov, A. A., Yuldasheva, G. B., & Avliyokulov, J. S. (2015). Technology of high-strength wear resistant fluorocomposites for mechanical engineering. Europäische Fachhochschule, (10), 43-47.
4. Nurmetov, K. I., & Riskulov, A. A. (2021). Some aspects of industrial polymer waste recycling system.
5. Алимухамедов, Ш. П., Рахимов, Р. В., Инагамов, С. Г., Мамаев, Ш. И., & Кодиров, Н. С. (2022). Математическое моделирование передаточного





- механизма потележечной тормозной системы грузовых вагонов. *Universum: технические науки*, (2-3 (95)), 8-14.
6. Алимухамедов, Ш. П., & Гапиров, А. Д. (2018). Напряженно-деформированное состояние устройства для гашения динамических нагрузок в трансмиссии транспортных машин. *Universum: технические науки*, (12 (57)), 23-28.
  7. Teleubaevich, U. T., Kayumjonovich, T. N., Pirmukhamedovich, A. S., & Muratovich, T. T. (2022). THERMODYNAMIC CALCULATION OF COMPLEX DEOXIDATION BY ALUMINUM AND SILICON OF MELTS OF STEEL 20GL FOR CAST PARTS OF ROLLING STOCK AUTOCOUPLE DEVICES. *Web of Scientist: International Scientific Research Journal*, 3(5), 1761-1771.
  8. Kayumjonovich, T. N., Pirmukhamedovich, A. S., & Teleubaevich, U. T. (2022). INFLUENCE OF COATING FORMATION CONDITIONS IN CHLORINE-CONTAINING MEDIA ON THE CORROSION PROPERTIES OF TITANIUM. *Web of Scientist: International Scientific Research Journal*, 3(5), 1692-1701.
  9. Kayumjonovich, T. N., Pirmukhamedovich, A. S., & Teleubaevich, U. T. (2022). JUSTIFICATION AND CHOICE OF RATIONAL OPERATING CURRENT FREQUENCY IN INDUCTION CRUCIBLE FURNACES. *Innovative Technologica: Methodical Research Journal*, 3(06), 40-47.
  10. Мухитдинов, А. А., & Алимухаммедов, Ш. П. Методическое указание к выполнению диссертационной работы на соискание ученой степени кандидата технических наук.
  11. Файзибаев, Ш. С., Авдеева, А. Н., Мамаев, Ш. И., Турсунов, Ш. Э., & Нигматова, Д. И. (2022). АНАЛИЗ ЭКСПЛУАТАЦИОННОЙ НАДЕЖНОСТИ ТЯГОВЫХ ЭЛЕКТРИЧЕСКИХ ДВИГАТЕЛЕЙ ЛОКОМОТИВОВ ОА “УЗБЕКИСТОН ТЕМИР ЙУЛЛАРИ”. *Universum: технические науки*, (4-5 (97)), 30-35.
  12. Файзибаев, Ш. С., Авдеева, А. Н., Мамаев, Ш. И., Турсунов, Ш. Э., & Нигматова, Д. И. (2022). МОДЕЛИРОВАНИЕ КРУТИЛЬНЫХ КОЛЕБАНИЙ КОЛЕСНО-МОТОРНОГО БЛОКА ТЕПЛОВОЗА UZTE16M. *Universum: технические науки*, (4-5 (97)), 24-29.
  13. Tursunov, S. E., & Tursunov, N. Q. (2022). TRANSPORT MASHINASOZLIGIDA ISHLATILADIGAN INNOVATSION O ‘LCHASH ASBOBLARI. *Academic research in educational sciences*, 3(TSTU Conference 1), 120-123.





14. RADKEVICH, M., SHIPILOVA, K., MYAGKOVA, N., ABDUKODIROVA, M., & GAPIROV, A. (2020, January). Assessment of some indices of environmental sustainability of transport in Tashkent. In Waste Forum (No. 1).
15. Гапиров, А. Д. (2015). Организация научной работы студентов по инженерным дисциплинам. Учёный XXI века, (12 (13)), 33-35.
16. Гапиров, А. Д. (2018). Современные тенденции защиты окружающей среды в автомобилестроении. Вопросы науки и образования, (3 (15)), 40-44.
17. Teleubaevich, U. T., Kayumjonovich, T. N., Pirmukhamedovich, A. S., & Muratovich, T. T. (2022). THERMODYNAMIC CALCULATION OF COMPLEX DEOXIDATION BY ALUMINUM AND SILICON OF MELTS OF STEEL 20GL FOR CAST PARTS OF ROLLING STOCK AUTOCOUPLE DEVICES. Web of Scientist: International Scientific Research Journal, 3(5), 1761-1771.
18. Kayumjonovich, T. N. (2022). DEVELOPMENT OF A METHOD FOR SELECTING THE COMPOSITIONS OF MOLDING SANDS FOR CRITICAL PARTS OF THE ROLLING STOCK. Web of Scientist: International Scientific Research Journal, 3(5), 1840-1847.
19. Ziyamukhamedova, U., Rakhmatov, E., & Nafasov, J. (2021, April). Optimization of the composition and properties of heterocomposite materials for coatings obtained by the activation-heliotechnological method. In Journal of Physics: Conference Series (Vol. 1889, No. 2, p. 022056). IOP Publishing.
20. ZIYAMUKHAMEDOVA, U., MIRADULLAYEVA, G., RAKHMATOV, E., NAFASOV, J., & INOGAMOVA, M. (2021). Development of The Composition of a Composite Material Based On Thermoreactive Binder Ed-20. Chemistry And Chemical Engineering, 2021(3), 6.
21. Ziyamuxamedova, U. A., Miradullaeva, G. B., Nafasov, J. H., & Azimov, S. J. (2022). RESEARCH OF RHEOLOGICAL PARAMETERS AND SELECTION OF COMPOSITIONS FOR APPLICATION ON WORKING SURFACES OF STRUCTURAL MATERIALS OF LARGE TECHNOLOGICAL EQUIPMENT. Web of Scientist: International Scientific Research Journal, 3(5), 1720-1727.
22. Alijonovna, Z. U. (2021, November). Research of Electrical Conductivity of Heterocomposite Materials for the Inner Surface of a Railway Tank. In International Conference On Multidisciplinary Research And Innovative Technologies (Vol. 2, pp. 174-178).
23. Urazbayev, T. T., Nafasov, J. H., & Azimov, S. J. (2022). Ti-Al SYSTEM COMPOUNDS TO CREATE A COMPOSITE TOOL MATERIAL. Web of Scientist: International Scientific Research Journal, 3(5), 1772-1782.







24. Nikolaevna, A. A. (2020). DISPUTED KINDS OF INFLUENCE IN THE PROCESS OF LEARNING AT THE UNIVERSITY. EPRA International Journal of Multidisciplinary Research (IJMR), 6(10), 496-498.
25. Мухаммадиева, Д. А., Валиева, Д. Ш., Тоиров, О. Т., & Эркабаев, Ф. И. (2022). ПОЛУЧЕНИЕ ПИГМЕНТА НА ОСНОВЕ ОСАДКОВ ЭЛЕКТРОХИМИЧЕСКОЙ ОЧИСТКИ ХРОМАТСОДЕРЖАЩИХ СТОКОВ. Scientific progress, 3(1), 254-262.
26. Тоиров, О. Т. У., Турсунов, Н. К., & Кучкоров, Л. А. У. (2022). Совершенствование технологии внепечной обработки стали с целью повышения ее механических свойств. Universum: технические науки, (4-2 (97)), 65-68.
27. Азимов, Ё. Х., Рахимов, У. Т., Турсунов, Н. К., & Тоиров, О. Т. (2022). Исследование влияние катионов солей на реологический статус геллановой камеди до гелеобразования. Oriental renaissance: Innovative, educational, natural and social sciences, 2(Special Issue 4-2), 1010-1017.

